

SIGRA IN ROCK MECHANICS

Sigra provides testing services and consulting in the field of rock mechanics covering coal and metalliferous mining, civil engineering and the petroleum industry.

The foundation of this capability is Sigra's ability to measure stress, stress change, movement, and pressure.

VIRGIN STRESS MEASUREMENT

In-Situ Stress Tool (IST)

Sigra measures in-situ rock stress primarily by the use of its IST tool. This is an overcore device which operates in conjunction with the Boart Longyear HQ wireline coring system and permits stresses to be measured at up to 1500 m depth. The tool is a re-usable device which returns high quality two dimensional stress information quickly where the rock stress is not high enough to cause rock breakage of the pilot hole. Most Australian coal mines have used the Sigra IST system as part of their exploration programmes.

Hydrofracturing

Where holes have already been drilled, Sigra uses its hydrofracturing system to determine the rock stress regime. This provides values of major and minor principal stresses even in cases where tensile stresses exist at the wall of the test hole. The system should be regarded as providing a lesser level of accuracy than the IST system at a greater cost. However in fractured ground it is the only way to gain an indication of stress across joints.

Borehole Breakout

Borehole breakout is used as an indicator of stress direction and stress magnitude. It is only of use where the stresses are great enough that they cause failure of the borehole wall, which can be detected by an acoustic scanner.

Surface Stress Measurement

While the above three techniques are for measuring stress at depth, Sigra also undertakes surface and near surface stress measurements. These involve strain-gauging the wall of a tunnel or mine opening and overcoring using a concrete coring system, so as to relieve the stress around the strain gauge. This technique has been used in excavations and within tunnels. The most notable of these is the Bogong Power project in the Snowy Mountains where four surface stresses were measured around the periphery of a circular tunnel created by a tunnel boring machine in granodiorite. These surface stress values permitted the calculation of the overall far field stress.

The surface stress is frequently a more important measurement than the virgin stress at depth as combined with rock strength, it provides an immediate estimate of the opening stability.

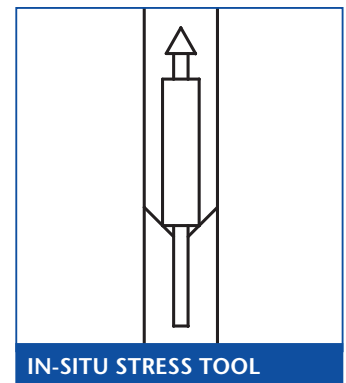

IN-SITU STRESS TOOL

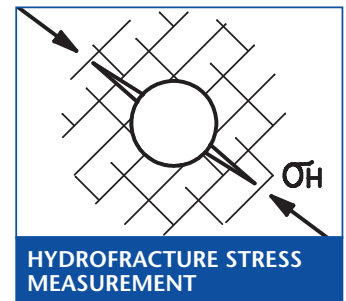

HYDROFRACTURE STRESS MEASUREMENT

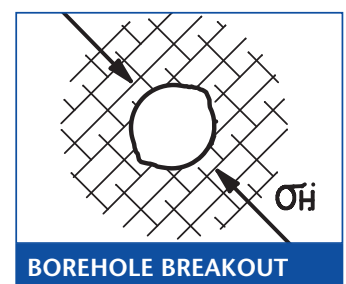

BOREHOLE BREAKOUT

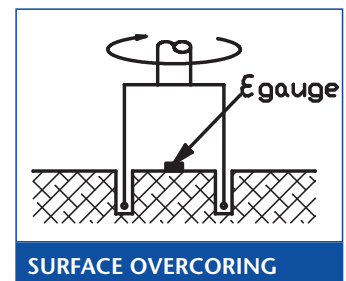

SURFACE OVERCORING

STRESS CHANGE MEASUREMENT

Sigra has the capability to measure stress change. This can be by installing and monitoring surface or near-surface strain gauges, or by cementing stress change cells in boreholes. The cementing process can be accomplished at great depth. Sigra have supplied and installed equipment to measure stress changes associated with dewatering and degassing of coal seams and to monitor the changing stresses around a fault in a longwall. Both installations used a stress change cell cemented at several hundred metres depth in a vertical borehole.

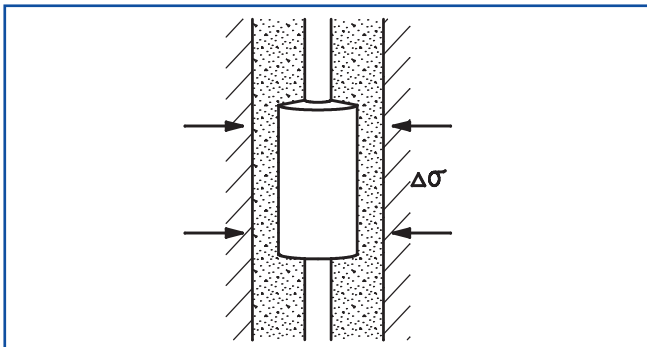

STRESS CHANGE CELL IN BOREHOLE

ROCK STRAIN AND MOVEMENT

Sigra can measure rock strain by strain gauge techniques utilising either resistance or vibrating wire strain gauges. One of the uses of strain measurement in a vertical borehole is in determining the stress versus strain behaviour of pillars in coal mining. Sigra can install multiple vertical strain gauges through the roof, pillar and floor. The strain changes in the roof and floor can be used with the mechanical properties of the rock to estimate the vertical stress changes while the pillar strain characteristic under the loading brought about by mining can be directly measured.

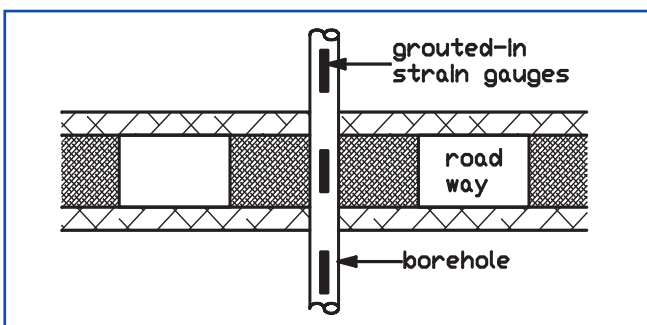

STRESS AND STRAIN OF COAL PILLAR

Extensimeters

Sigra can supply and fit conventional wire based extensionmeters. More recently though, an easily visible system to measure rock movement underground has been developed. This is based on clear plastic tubing which is filled with a fluorescent gel which is extruded along the tube with movement of a doughnut extensimeter or by a convergence measuring system. Movement can be read highly accurately (<0.04 mm) with reasonable measurement care. An indication of movement can be obtained quickly by flashing a cap lamp on the tubing. Used in this manner the system provides a quick indicator of movement and imminent failure.

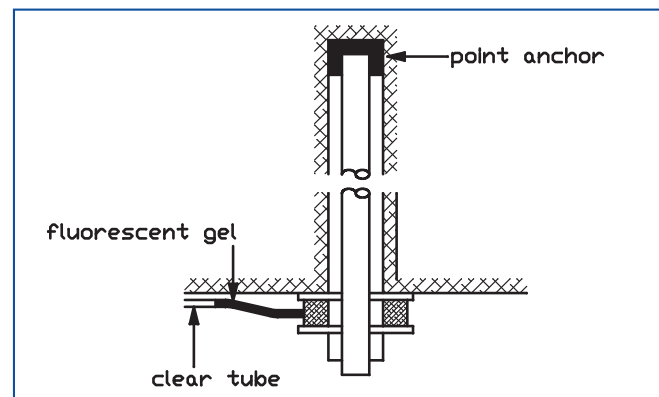

DOUGHNUT EXTENSIMETER

Instrumented Rock Bolts

Sigra manufacture, install and monitor instrumented rock bolts. These serve to detect the loading on a bolt over its length throughout its operational life. They are particularly useful in detecting if the bolt is loaded from roof delamination and in determining the effects of pre-loading of the bolt.

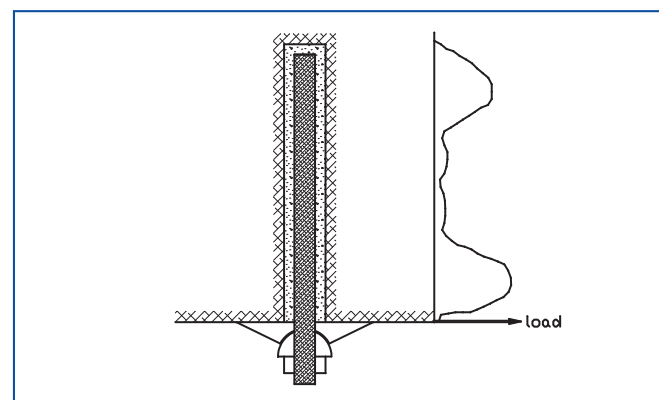

INSTRUMENTED ROCK BOLT

FLUID PRESSURE MEASUREMENT

The measurement of fluid pressure in rock is an essential part of determining the effective stress regime that exists. To enable this Sibra has various techniques for measuring fluid pressure in rocks. These involve the use of grouted-in pressure sensing points (with or without transducers) and the use of packer based systems for zone isolation in pressure measurement.

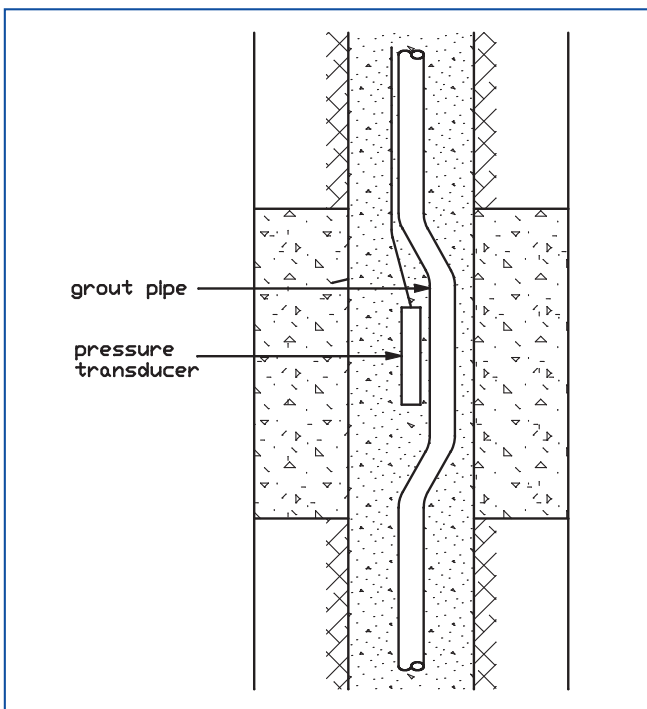

ROUTED-IN PIEZOMETER

MICROSEISMIC MONITORING

Sibra have recently installed a system that gathers information from 14 geophones via four seismographs and 6 stress change cells and transmits this information to a site computer. This information is uploaded to the internet so as to permit the determination of the extent of the effects of longwall mining. Alarm capabilities have been installed as an integral part of the system.

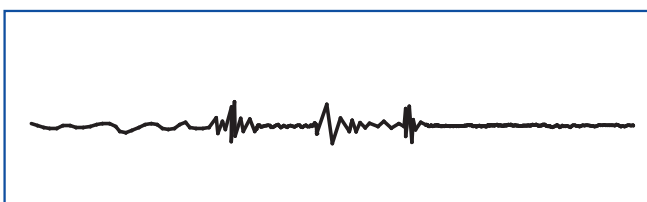

MICROSEISMIC EVENTS

Data Handling

Supporting Sibra's array of monitoring equipment is a sophisticated data acquisition system including software to gather this information into a database which can be remotely accessed via the internet. The foundation of this system is Sibra's Field Data Logger which is ideally suited to geotechnical applications. This device has logger to logger radio communication and the capability to communicate via modem to the mobile or land line phone network. Sibra has other data acquisition systems suitable for the underground environment or for high speed data acquisition.

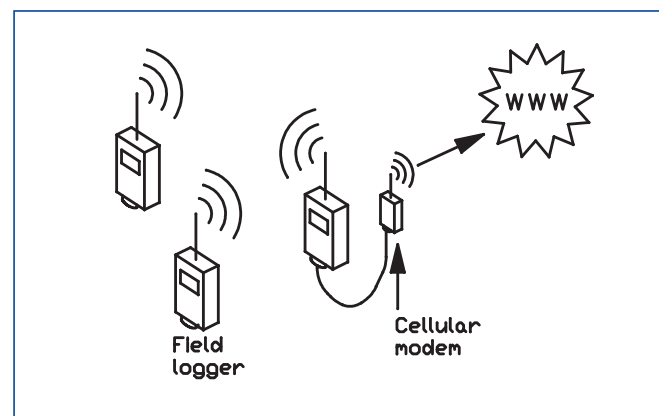

FIELD DATA LOGGERS AND CELLULAR MODEM

Rock Properties

Sibra undertakes uniaxial and triaxial testing of rock specimens. Particular emphasis is placed on the triaxial stress strain behaviour of coals. The modulus of these has been found to be very highly related to the confining stress. This has significant implications for all rock mechanics design in coal and in the estimation of energy storage within coal that may contribute to bumps or outbursts.

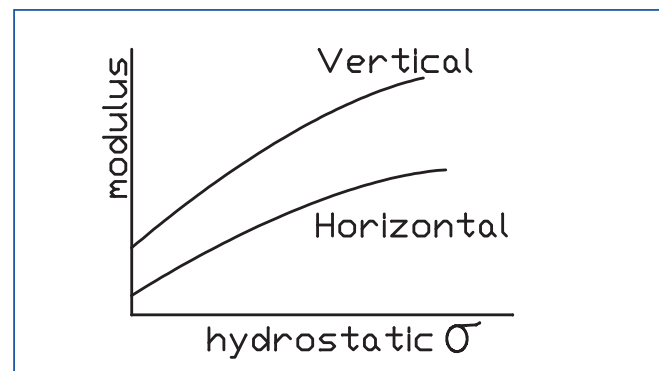

COAL MODULUS VS HYDROSTATIC STRESS

DESIGN

Sigra provide a design service to cover the range of applications of rock mechanics. These extend from the design of pillars and roof support systems in underground mining to applications in the petroleum industry.

The petroleum applications include assessing the stability of directional boreholes in a triaxial stress field and the likely effects of hydrofracture used in the stimulation of wells.

In the field of mining and civil rock mechanics the concepts of reinforced rock using passive and actively prestressed reinforcement and in particular the development of structural beams through rock bolting combined with tensile surface reinforcement are areas of special interest.

The company also possesses a breadth of experience in dewatering as a means of rock slope stabilisation from both the theoretical and practical viewpoints.

Modelling

Sigra has a numerical modelling capability for determining the stability of openings created in rock. It must be remembered however that models are useful but without measurements they are difficult to validate and have limited credibility.

Tectonic Strain

Sigra has successfully introduced and used over many years, the concept of tectonic strain to explain the distribution of stress through laminated strata of varying stiffnesses. In this varying stress measurements through a sedimentary sequence are corrected for self weight induced stress under zero lateral strain conditions to yield values of tectonic stress induced by tectonic strains. The tectonic stress is variable and related to the rock stiffness while the tectonic strain required to induce the tectonic stress is usually fairly consistent. Tectonic strain values form the basis for determining the stresses throughout the sequence when used in combination with the Young's modulus and Poisson's ratio.

